

ASSEMBLE THE SHELTER INCLUDING THE SEATING. PLACE IN THE REQUIRED POSITION. MARK THE ANCHOR HOLE POSITIONS. MOVE THE SHELTER TO DRILL THE HOLES. REPOSITION THE SHELTER AND INSERT THE SCREWS.

THE SHELTER CONSISTS OF UPRIGHT SUPPORTS, SCREEN FRAMES AND BENCH SEATING PLANKS.

- \* HOLD TWO UPRIGHT SO THE SCREEN WILL FIT BETWEEN THEM.
- \* PLACE THE TWO LUGS ON THE BOTTOM OF THE SCREEN INTO THE LUGS ON EACH UPRIGHT.
- \* ROTATE THE SCREEN UPWARD TILL IT FITS FLUSH WITH THE UPRIGHT.
- \* INSERT TWO BOLTS, WASHERS AND SPRING WASHERS THROUGH THE SCREEN FRAME AND INTO THE UPRIGHTS.
- \* AFTER THE SHELTER IS ASSEMBLED, ALIGN ALL THE UPRIGHTS USING THE SEAT AND BACKREST PLANKS.
- \* REMOVE THE TAPE COVER FILM AND REINSTALL THE SEAT AND BACKREST.
- \* ADJUST THE POSITION OF THE SHELTER ON THE SLAB AND MARK THE HOLE POSITIONS ON THE SLAB.
- \* DRILL 12MM X 100MM ANCHOR HOLES AND BOLT THE SHELTER IN PLACE USING 12MM X 150MM CONCRETE SCREWS.

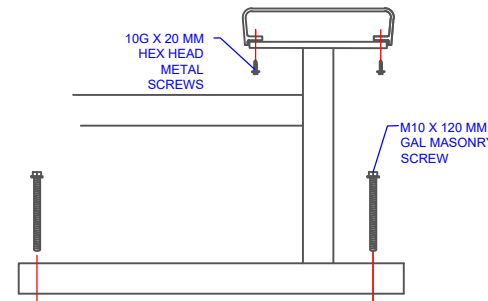
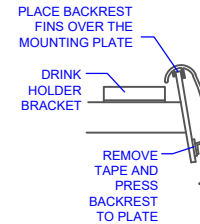
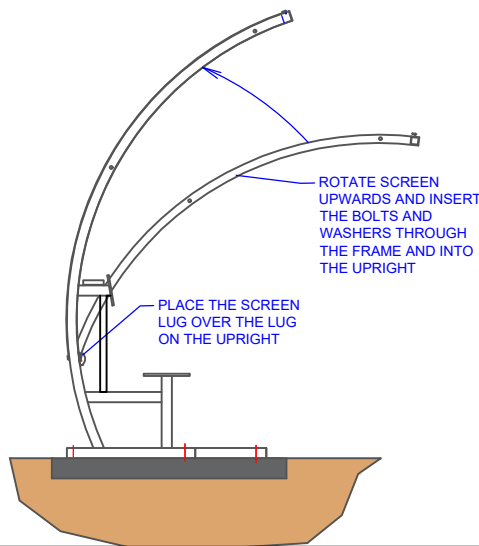

PART	ITEM DESCRIPTION	QTY	PACKED
1A	LEFT END PANEL	1	
1B	RIGHT END PANEL	1	
2	CENTRE UPRIGHT	5	
3	SCREEN FRAME	6	
4	SEAT PLANK 3335 MM	2	
5	SEAT BACKREST 3335 MM	2	
6	SEAT END CAP	2	
7	BACKREST END CAP	2	
BOLT KIT			
24	M10 X 60 S/S BUTTON HEAD BOLT, M12 MUDGUARD WASHER, S/WASHER		
14	HEX HEAD METAL SEAT SCREWS		
14	M12 X 150 MM CONCRETE SCREWS		
21	50 X 50 MM THICK WALL END CAPS		

TITLE: <b>AURORA 12 PLAYER SHELTER</b>	
DRAWING NUMBER: <b>ASSEMBLY</b>	
WEIGHT: <b>230 KG</b>	# OF PACKAGES <b>-</b>
ORDER PACKED BY: <b>-</b>	



**Oz Ring Pty Ltd**  
 Trading as:  
**Play Hard Sports Equipment**  
 ABN 79 066 094 559  
 24 Ern Harley Drive  
 Burleigh Heads Qld 4220  
 Phone: (07) 5593 4494  
 Fax: (07) 5593 4338  
 Website: [www.playhardsports.com.au](http://www.playhardsports.com.au)  
 Email: [email@playhardsports.com.au](mailto:email@playhardsports.com.au)