

ASSEMBLY INSTRUCTIONS

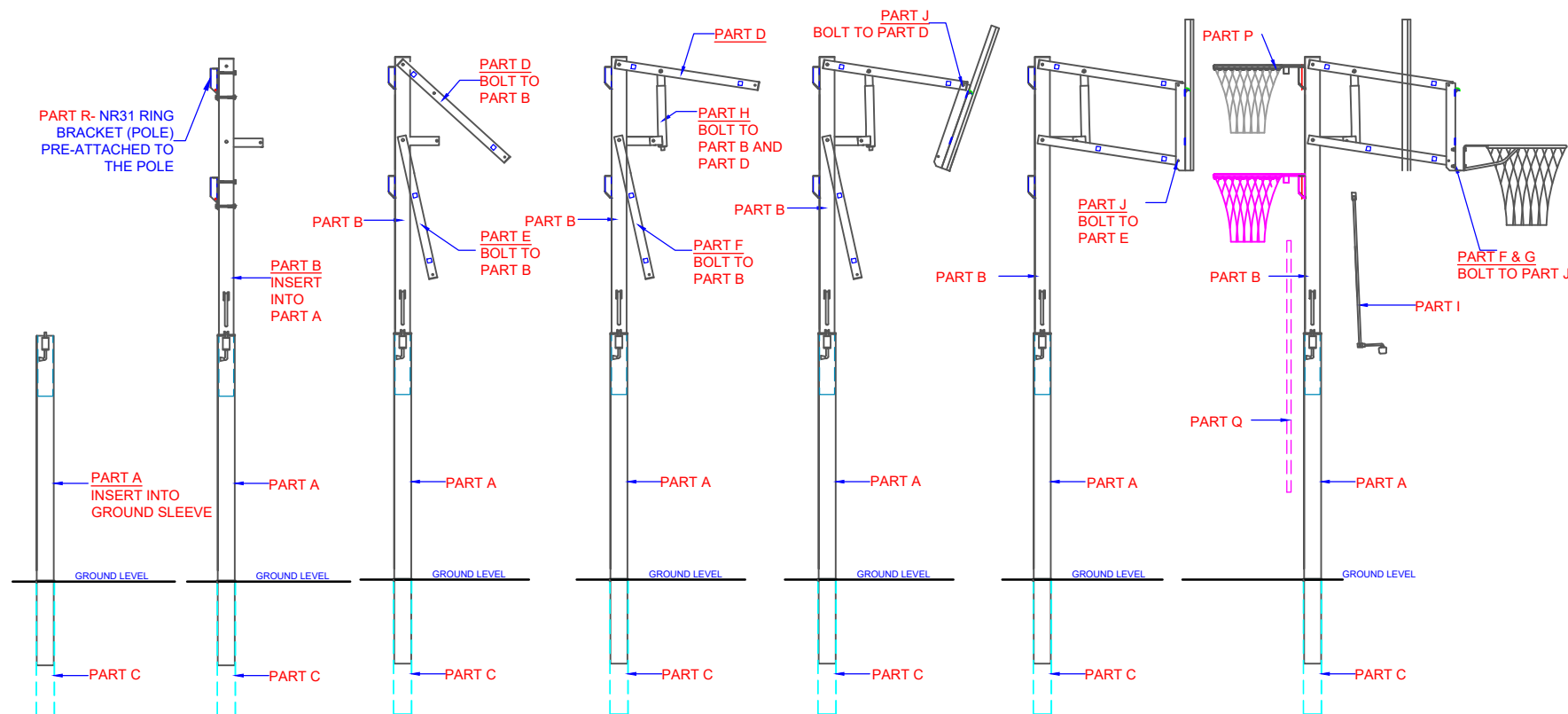

USE A SPIRIT LEVEL TO MAKE SURE THE SLEEVE IS VERTICAL

CENTRE OF SLEEVE TO BACKBOARD DISTANCE IS APPROX. 750MM

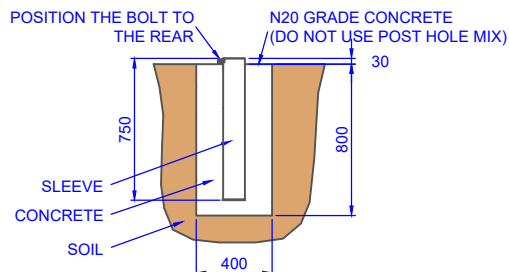

TITLE:

**GAME CHANGER
BASKETBALL TOWER**

DRAWING NUMBER:

GAME CHANGER ASSEMBLY 2 OF 3



Oz Ring Pty Ltd

Trading as:

Play Hard Sports Equipment

ABN 79 066 094 559

24 Ern Harley Drive

Burleigh Heads Qld 4220

Phone: (07) 5593 4494

Fax: (07) 5593 4338

Website: www.playhardsports.com.au

Email: email@playhardsports.com.au