



2/2/2025

# FORCE 10 BASKETBALL UNIT

Installation, Operation &  
Maintenance Manual

**PLAY HARD SPORTS EQUIPMENT**

13 Alex Fisher Drive  
Burleigh Heads, QLD 4220

# Contents

---

Introduction .....	2
Product Details: .....	2
Safety Information for the Installer: .....	3
Important Safety Information .....	4
Assembly Precautions.....	4
Site Specific Precautions:.....	4
Footings Details .....	7
1. Force10 Footing Details.....	7
2. Force10-BP Footing Details .....	8
3. Force10 (Sleeve) Footing Details.....	9
Installation Instructions: .....	10
Maintenance:.....	12
Safety Guidelines .....	12
Certificate of Compliance: .....	13
Warranty Certificate: .....	14

## Introduction

Thank you for choosing the Force 10 Basketball System from Play Hard Sports Equipment Australia. Our Force 10 Towers are designed for durability and performance and are suitable for residential use. This manual provides detailed information on the installation, maintenance, usage, and warranty details of the Force 10 Basketball Tower supplied by Play Hard Sports Equipment Australia.

### Product Details:

Force 10 Basketball Towers are designed and manufactured by Play Hard Sports Equipment using Structural Grade Galvanised Steel. The tower has been load-tested, engineered, and certified by Structural Engineers. The Tower has been designed to be used in the home or residential courts as the extension arm can fit over a standard 3.0-meter-high fence.

### Product Specifications:

- **Models:**
  - Force 10,
  - Force 10 – BP (on a Base Plate)
  - Force 10 (Sleeve)
- **Height:**

**Standard Ring/Hoop Height:** 3.05 meters; can be modified for junior height with the addition of SHF18 height adjusting frame (optional).
- **Footing Option:**

Depending on the model, the tower can be concreted directly into the ground, in a ground sleeve or base-plated with chemset anchor studs.
- **Footing Size:** 400 Diameter 800mm Deep Bored Pier with N20 Concrete.
- **Material:** Galvanized steel with high gloss black paint coating.
- **Basketball Ring:**
  - R11b/ProRim
  - OzRing
- **Net Tie System:** Patented Waverail system.
- **Backboard:** Regulation Size 1800mm x 1050mm
  - B1810p: Polyboard Backboard
  - B1810a: Acrylic Backboard
  - B1810g: Glass Backboard
- **Color Options:** Standard Hi-Gloss Black Paint. Various paint colors are available on request.
- **Padding Options:** BP125S
  - 2.06m high x 360 mm round cylindrical foam.
  - Vertical Velcro Seam at the rear.
  - Multiple colours are available, and your logo can be added too.

Apart from our standard product range, we offer custom basketball towers based on site-specific requirements. Please contact our team for further details.

All our product footings have been engineered to be suitable for site soil classification as Class 'A', 'S' & 'M' per AS2870. Site-specific footing and slab engineering must be done for other Soil Classes. We also offer site-specific engineering drawings if required for an additional charge.

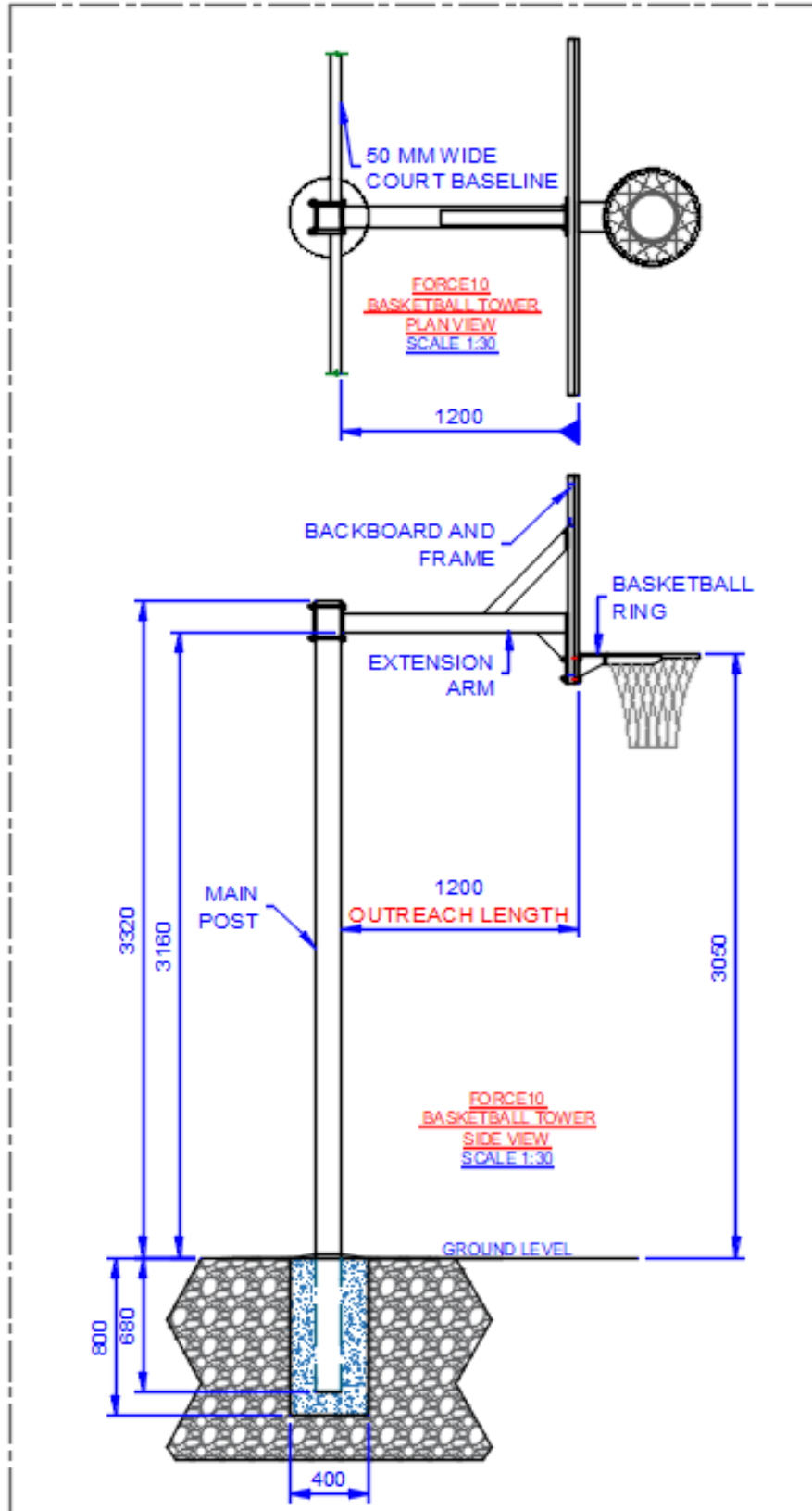

Figure 1: Force10 Basketball Tower

## Safety Information for the Installer:

### Important Safety Information

- **Read the Manual:** Ensure you read this manual in full before beginning assembly or installation.
- **Supervision:** Children should be supervised around the tower location during and after installation.
- **Wear Safety Gear:** Always wear appropriate safety gear during assembly and installation.
- **Avoid Electrical Hazards:** Keep electrical tools away from the goalposts and ensure the work area is dry.

### Assembly Precautions

- **Two-Person Job:** Assembly requires at least two people to ensure safety and accuracy.
- **Check Parts:** Verify all parts are present and undamaged before starting assembly.
- **Level Ground:** Assemble on a flat surface to avoid instability.

### Site Specific Precautions:

- Before commencing any groundwork, please survey the ground/field for underground electrical, water, or sewage lines and check for overhead electrical lines.
- It is advised that the soil is tested to know its strength. All our towers have been structurally designed to suit 'A', 'S' & 'M' Soils per AS2870. The contractors/installers must notify Play Hard Sports Equipment of any changes to the site specification. All other soil sites would require site-specific footing and slab engineering design.
- The concrete must be of a minimum 20 MPA, with a slump of 80 – 100 mm, and a maximum aggregate of size 20mm.
- Let the concrete set for at least 4 days before commencing further work.

## Component List

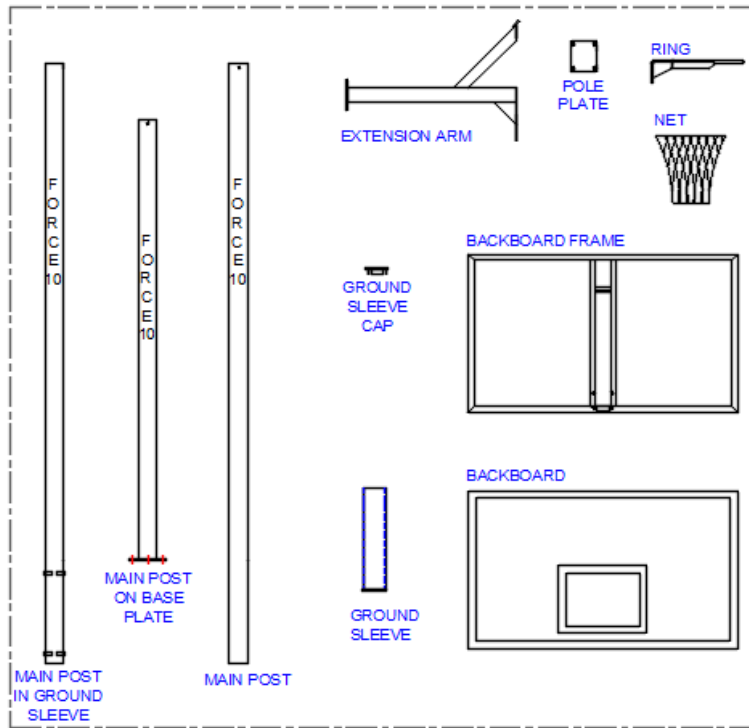

Figure 2: Force 10 Basketball Tower Part Lists

Components	Quantity per Tower		
	Force 10	Force 10 - BP	Force 10 (Sleeve)
Main Post	1	1	1
Extension Arm	1	1	1
Pole Plate	1	1	1
Backboard Frame	1	1	1
Ring	1	1	1
Ground Sleeve	0	0	1
Sleeve Cap	0	0	1
<b>Bolt Kit</b>			
M16 x 180 mm H.T. Gal Hex Bolt, Spring Washer, Flat Washer and Nut	4	4	4
M10 x 90mm Gal Hex Bolt, Spring Washer, Double Flat Washer & Nut	4	4	4
M16 Threaded Rods or Chemset Reo 502 with levelling Nut and Washer (Not Included in the Package)	0	6	0

Note: Pole Plate and bolt kits are packed inside the ring box. Please check your order. If any parts are missing, please call us immediately



## Footing Details

### 1. Force10 Footing Details

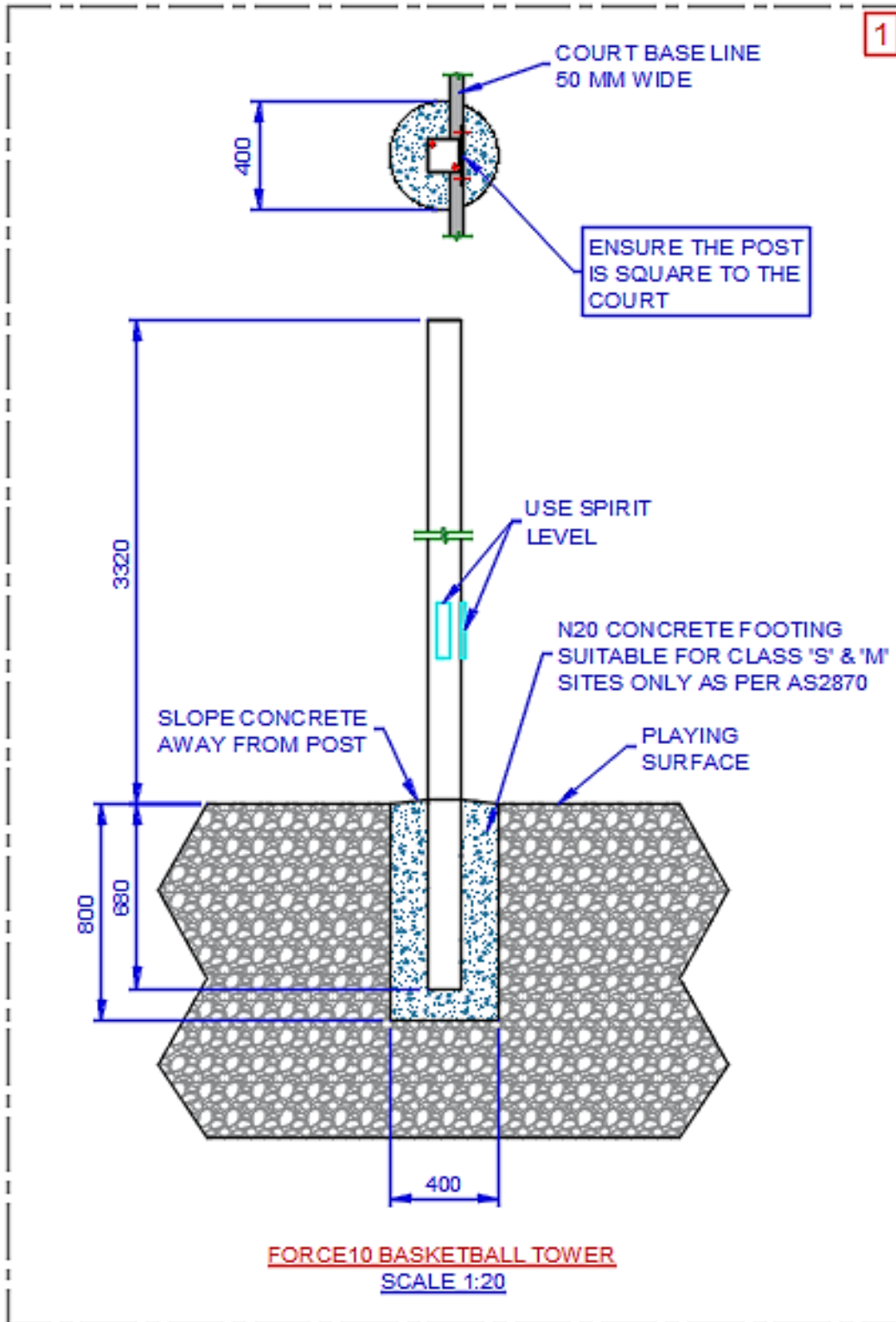

Figure 3: Force 10 Footing Detail

13 Alex Fisher Drive, Burleigh Heads, QLD 4220 (Australia)

Ph: 1300 851 518 | +61 7 5593 4494

Email: [email@playhardsports.com.au](mailto:email@playhardsports.com.au) | W: [www.playhardsports.com.au](http://www.playhardsports.com.au)



## 2. Force10-BP Footing Details

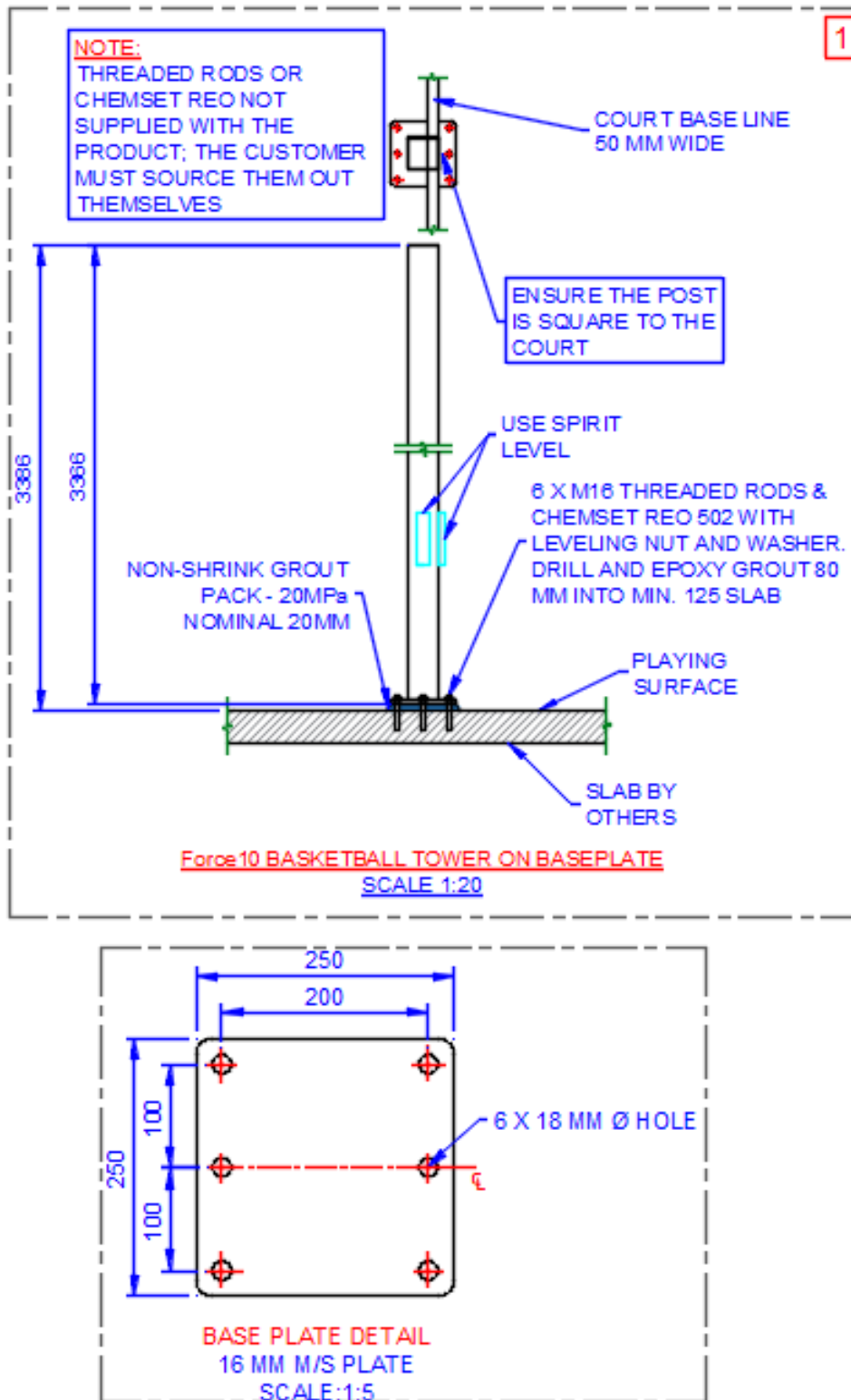

Figure 4: Force 10-BP Footing Detail

### 3. Force10 (Sleeve) Footing Details

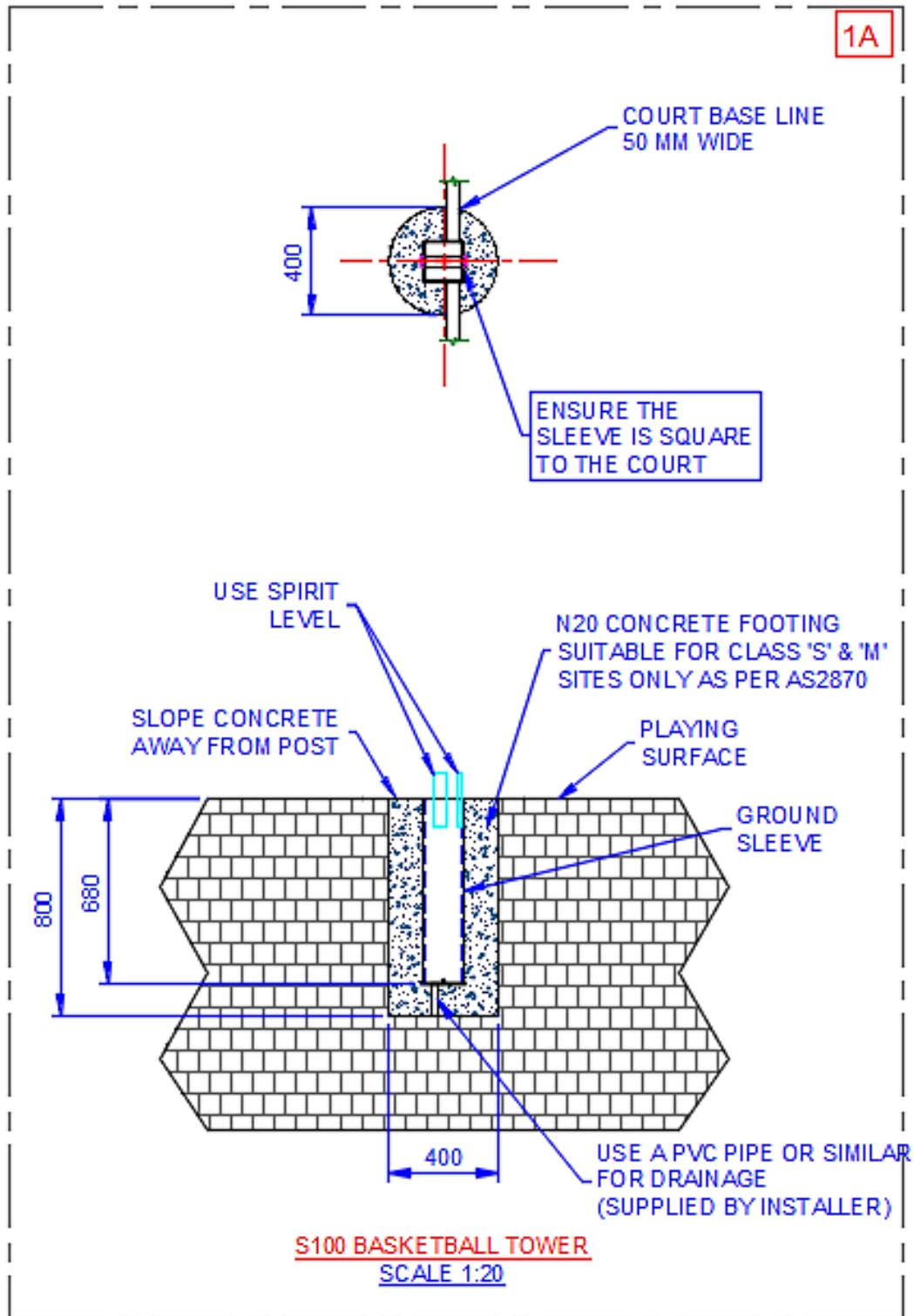

Figure 5: Force 10 (Sleeve) Option

## Installation Instructions:

### 1A. Site Preparation:

- Before commencing any groundwork, please survey the ground/field for any underground electrical line, water line and sewage line. Also, check for any overhead electrical lines.
- It is advised that the soil is tested to know its strength. All our towers have been structurally designed to suit 'A', 'S' & 'M' Soils per AS2870. The contractors/installers must notify Play Hard Sports Equipment of any changes to the site specification. All other soil sites would require site-specific footing and slab engineering design.

### 1B. Post Installation:

#### A. Force 10 Concreted to the ground:

- Bore Drill a 400 mm Diameter and 800 mm Deep Hole.
- If the Ground Level at the hole position is lower than the playing surface, then box up around the hole site to achieve the concrete depth of 800mm. (*Please be mindful that only 100mm of box-up is acceptable*)
- Insert the main post into the hole and ensure it is centred, correctly oriented and at a correct distance from the basketball court.
  - *Please refer to Figure 1 for further details. The post must be installed in a specific orientation as shown in the Figure and it is the Installer/Contractor responsible for ensuring that.*
- Pour the concrete into the hole. (*Prevent any concrete from getting inside the post*)
- Ensure the post is fixed while pouring the concrete into the hole.
- The concrete must be of a minimum 20 MPA, with a slump of 80 – 100 mm, and a maximum aggregate of size 20mm.
- Trowel the concrete sloping away from the pole to prevent water from pooling around the post base.
- While the concrete mix is still fresh, use spirit level to check that the post is level in all axes.
- Let the concrete set for at least 4 days before commencing further work.

#### B. Force 10-BP:

- Select the position where you want to install your tower. If the slab is not levelled, use a 20mm non-shrink grout-20MPa to set it level.
- Then position the post with the court baseline and mark the hole position for the anchors.
- Drill the holes as specified in the anchor bolts specification.
- Clear the holes of any dust particles.
- Then install the post into the holes using the threaded rods and epoxy grout.
- Use a spirit level to check the post is correctly installed.

#### C. Force 10 in the Ground Sleeve:

- Bore Drill a 400 mm Diameter and 800 mm Deep Hole.
- Insert the Ground Sleeve in the hole. Ensure it is centred and at level with the playing field ground level.

- Pour the concrete into the hole. (*Prevent any concrete from getting inside the ground sleeve*).
- If the Ground Level at the hole position is lower than the playing surface, then box up around the hole site to achieve the concrete depth of 800mm. (*Please be mindful that only 100mm of box-up is acceptable*)
- The concrete must be of a minimum 20 MPA, with a slump of 80 – 100 mm, and a maximum aggregate of size 20mm.
- Trowel the concrete sloping away from the pole to prevent water from pooling around the post base.
- Let the concrete set for at least 4 days before commencing further work.
- Then Insert the main post into the ground sleeve.

## 2. Attaching Extension Arm:

- Once the concrete is set, attach the Extension Arm to the Post.
- Use the supplied Pole Plate and M16 X 180MM H.T. Gal Hex Bolt to attach the Extension Arm.
- Align the bolt holes and insert the nuts without damaging the bolt threads.
- Run all the nuts up the bolt shaft until finger tight and use wrenches to tighten the bolts to achieve a snug fit.

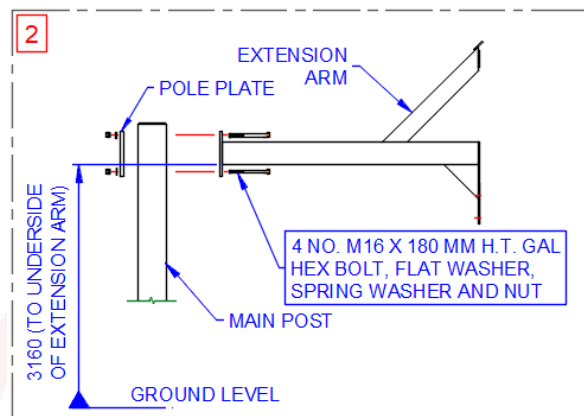

## 3. Attaching the Backboard:

- To attach the backboard, hang the frame via an angled bracket at the back end of the frame on top of the bracket at the extension arm.

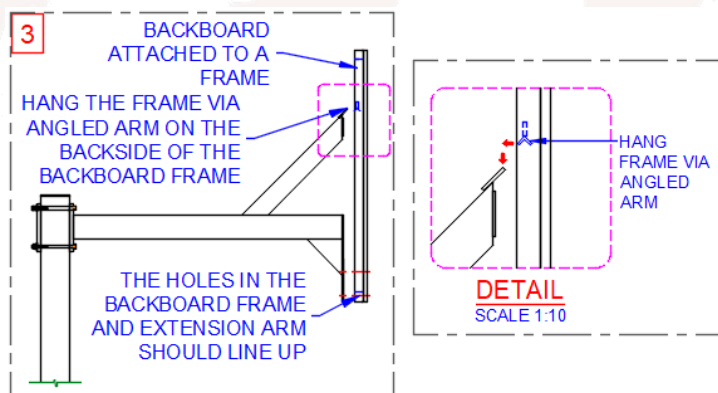

#### 4. Attaching the Ring

- Align the bolt holes in the backboard, the extension arm and the ring and insert the M10 x 90mm Gal Hex Bolt, Double Flat Washer, Spring Washer and Nut without damaging the thread.
- Run all the nuts up the bolt shaft until finger tight and use wrenches to tighten the bolts to achieve a snug fit.

*Note: Use anti-seize lubricants on all bolts during the installation process.*

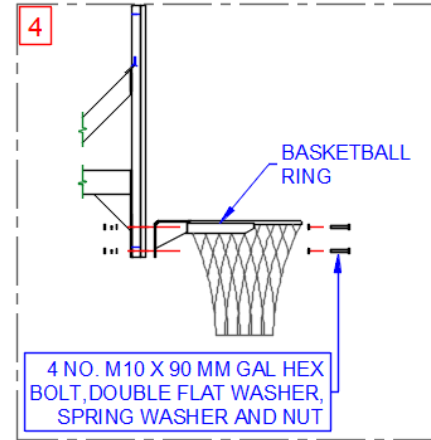

### Maintenance:

All our towers are designed to require a minimal level of maintenance. However, it is advisable to do:

- **Regular Inspections:** Check for any signs of wear or damage. Tighten bolts and replace nets or padding as needed.
- **Cleaning:** Clean the posts with a damp cloth to remove dirt. Avoid harsh chemicals that could damage the paint. If the poles have been scratched over the intended period of use, lightly scuff the area and apply 2 coats of black gloss paint (spray painted) or your choice of color.
- **Weather Protection:** Consider using protective covers during extreme weather to extend the lifespan of the equipment.

### Safety Guidelines (Usage)

The owner of this equipment is responsible for ensuring all players are aware of these conditions for the safe use and operation of the equipment.

1. **Padding:**
  - Ensure padding is securely attached to reduce injury risk.
2. **Supervision:**
  - Supervise play, especially with younger players, to ensure safety.
  - Prevent players from hanging from the ring or climbing up the posts to prevent serious injury.
3. **Height Adjustment:**
  - If there is an option for a height height-adjusting frame, care must be taken while operating the height-adjusting mechanism.
4. During visual inspection, if the bolts are loosened or the post or footing is damaged, the basketball system should not be used until they have been repaired.

## Certificate of Compliance:

All our products have been structurally designed and are made using structural-grade steel. All the workmanship is completed following the relevant Australian Standards. Our Products comply with the following Australian Standards.

1. AS/NZS 4100:1998 Steel Structures
2. AS/NZS 1554.1:2014 Welding of steel structures
3. AS/NZS 1664 Aluminium structures
4. AS/NZS 1665:2004 Welding of aluminium structures
5. AS/NZS 1170.0 Structural design actions – General principles
6. AS/NZS 1170.2 Structural design actions – Wind actions
7. AS/NZS 2312.1:2017 Guide to the protection of structural steel against atmospheric corrosion by the use of protective coatings
8. AS/NZS 2311:2017 Guide to the paintings of buildings
9. AS/NZS 4680:2006 Hot-dip galvanized (Zinc) coatings on fabricated ferrous articles

All our Basketball Towers meet the QLD Education specifications for basketball equipment. April 2023. All our towers have been load and cycle tested according to those specifications, which are the most stringent tests required in any State in Australia  
All our products are designed and manufactured here in Australia.





## Warranty Certificate:



*When you purchase a Play Hard Sports Equipment product you have the peace of mind in knowing that your product is covered by Play Hard Sports Equipment's manufacturer's warranty against faulty workmanship and materials.*

*The Force 10 Basketball Tower Structure has 10 years of warranty. The Backboard has a 10-year warranty, The ProRim has a 25-year warranty, OzRing has a 10-year warranty and there is a 2-year warranty for the padding and a year for the nets.*

*The warranty covers damage or failure of the product during normal intended use. The warranty does not include damage to the product resulting from accident, misuse, improper installation, operation, or unauthorised repair or alteration. Products manufactured for home use are not guaranteed for use in commercial applications.*

*If the product should become defective within the warranty period, please get in touch with Play Hard Sports Equipment customer service:*

24 Ern Harley Drive  
Burleigh Heads QLD 4220  
Ph: (07) 55934494  
Fax: (07) 55934338  
Email: [email@playhardsports.com.au](mailto:email@playhardsports.com.au)